

Heidelberg Wallbox Home Eco

Safety instructions

00.999.3028/01

HEIDELBERG

A Safety instructions

Safety instructions	A.1.1
1 Safety instructions for the Wallbox "Home Eco"	A.1.1
1.1 Note to the owner and operator of the charging system	A.1.1
1.2 Intended use	A.1.1
1.3 Notes for people with a pacemaker (PM) or implantable cardioverter defibrillator (ICD)	A.1.3
1.4 Working on the charging system without risk	A.1.3
1.5 Installation and tests	A.1.4
1.6 Specifications	A.1.7
1.7 Protective devices	A.1.8
1.8 Operator control elements	A.1.9
1.9 Declaration of Conformity	A.1.9

1 Safety instructions for the Wallbox "Home Eco"

1.1 Note to the owner and operator of the charging system

- Read the operating manual before starting up the charging system.
- Ensure that all persons working on or using this charging system
 - have read the operating manual,
 - follow the regulations and instructions for working without risk.
- Keep the equipment documentation at a location where it is always accessible to the operators of the charging system.
- Ensure that no unauthorized persons can access the charging system.

1.2 Intended use

The charging system is intended for use in private and semiprivate areas, e.g. private properties, corporate parking areas, or depots.

Do not use the charging system where explosive or combustible substances (e.g. gases, liquids, or dusts) are stored or are present.

The charging system is intended exclusively for charging electric vehicles.

- Charging in accordance with type 3 of IEC 61851-1
- Plug-and-socket connectors in accordance with IEC 62196
- The charging system is intended for use only in TT, TN-C, and TN-C-S networks. The charging system must not be operated in IT networks.

The charging system is not suitable for charging vehicles with outgassing batteries (e.g. lead-acid batteries).

The charging system is operated as an individual station without a superordinate control system. The charging system is intended exclusively for stationary installation.

The charging system may only be operated and used by persons who have read the operating manual.

The electrical installation, start-up, and maintenance of the charging system may only be performed by qualified electricians who have been correspondingly authorized by the operator.

The qualified electricians must have read and understood the equipment documentation and must comply with its instructions.

Requirements regarding the qualification of electricians

Knowledge of and compliance with the 5 safety rules for working with electrical installations:

- isolate.
- secure against reactivation.
- check absence of voltage.
- ground and short-circuit.
- cover or block off live parts in the vicinity.

Reactivation is carried out in reverse order.

- Knowledge of the general and special safety regulations and accident prevention regulations.
- Knowledge of the relevant electrotechnical regulations e.g. checks associated with commissioning and the requirements for operating facilities, rooms, and special types of equipment - power supply for electric vehicles.
- Ability to recognize risks and to avoid potential hazards.

When installing and handling the charging system, the user, the operator, and the electrician must comply with the national regulations on safety and accident prevention.

Improper use and non-compliance with the operating manual may jeopardize:

- your life
- your health
- charging system and vehicle.

Safety devices on the charging system

- must not be removed,
- must not be manipulated,
- must not be bypassed,
- before each use, it must be checked that the equipment (e.g. housing, connecting line, charging coupler) is undamaged,
- must be repaired or replaced as necessary, in order to preserve the functional properties.

Ensure that:

- safety identifications, e.g. yellow-colored marks,
- danger signs and
- safety lights

remain easily visible and retain their effectiveness.

- When operating the charging system, do not use any extension cables, cable reels, multisocket power strips, or travel adapters.
- Do not insert any objects into the charging coupler of the charging system.
- Protect the socket-outlets and plug-in connections against moisture and water or other liquids.

- Never immerse the charging system or the charging coupler in water or other liquids.
- Do not disconnect the charging coupler from the vehicle during charging.

Heidelberg takes responsibility only of the charging system in its delivered condition and for any work performed by skilled Heidelberg personnel.

1.3 Notes for people with a pacemaker (PM) or implantable cardioverter defibrillator (ICD)

Charging systems from Heidelberg that are operated as intended, comply with the European guideline on electromagnetic compatibility regarding radiated interference.

Should people with a pacemaker (PM) or implantable cardioverter defibrillator (ICD) wish to conduct activities on charging systems and their devices in the intended manner, Heidelberg is not in a position to make any statement regarding the suitability of such medical devices. Heidelberg is not able to assess the pacemakers or concerned implantable cardioverter defibrillators with regard to their susceptibility to electromagnetic radiation. This is something that only the manufacturers of the pacemaker or implantable cardioverter defibrillator can do.

Heidelberg therefore recommends only allowing the people in question to work on its charging systems after consultation with the manufacturer of the pacemaker/defibrillator and the relevant insurance company. Ensure at all times that no health or safety risks are involved.

► **Note**

People with a pacemaker or defibrillator may not work on or stand near the charging systems and their devices, e.g. to perform maintenance operations or rectify any faults.

1.4 Working on the charging system without risk

Before plugging the charging coupler into the vehicle

- The connecting line of the charging system must be completely unwound.
- Check whether the housing of the charging system, the connecting line, the charging coupler, and the connectors are undamaged.
- Take hold of the plug-in connection of the charging system only on the charging coupler and not on the charging cable.
- Ensure that no-one can trip e.g. over the charging cable.

During the charging process

- Keep unauthorized persons away from the charging system.
- When the charging system is connected, you must not clean or wash the vehicle with a high-pressure cleaner because the plug-in connection is not sealed against pressurized water.

In case of malfunctions or failure of the charging system

- Disconnect the charging system from the power supply by switching off the respective circuit breaker in the building. Leave a sign with the name of the person authorized to switch on the circuit breaker.
- Call in a qualified electrician immediately.

Electrical devices

- The housing of the charging system must always be kept closed.

1.5 Installation and tests**Information for selecting protective devices for basic and fault protection against touching directly or indirectly**

- **Electrical circuit breakers**

The charging system must be protected with circuit breakers in compliance with the respective national regulations. This depends, for example, on the required tripping time, internal network resistance, conductor cross-section, conductor lengths, and the preset rating of the charging system.

The short-circuit protection of the conductor must have a characteristic that permits 8-10-fold of the I_{nom} value and must not exceed a maximum nominal current of 16 A, depending on the preset rating of the charging system.

- **Residual-current circuit breaker**

For reasons of personal safety, national regulations may stipulate an upstream RCD with an $I_{\Delta N}$ of 30 mA AC. Choose a suitable RCD that complies with the national regulations. For this, please refer to the comments in the sections *DC and AC residual-current detection*.

- **DC residual-current detection**

The charging system is equipped with 6 mA DC residual-current detection. The charging system switches itself off if there is a residual current that is greater than or equal to 6 mA DC. Details of this are given in the *Diagnostics* section.

- **AC residual-current detection**

The charging system is equipped with integrated AC residual-current detection as a convenience function.

This residual-current detection switches off the charging system, at the latest, if there is a residual current greater than 30 mA AC. Details of this are given in the *Diagnostics* section.

Notwithstanding this convenience function, a short-acting RCD must be connected upstream of the charging system, if necessary. The AC residual-current detection is not a substitute for an RCD.

Information on initial inspections after installation and repeat inspections

National regulations may stipulate inspections of the charging system before start-up and at regular intervals. Perform these inspections in accordance with the respective rules and regulations. Information is given below on how these inspections can be performed.

- **PE conductor test**

After the installation and before switching on for the first time, test the continuity of the PE conductor. For this, connect the charging coupler to a test adapter for vehicle simulation in accordance with EN 61581-1. Measure the resistance of the PE conductor between the PE conductor socket of the adapter and the connection point of the PE conductor in the building's electrical cabinet. The value of the PE conductor for a total conductor length (connecting line to the charging system and the vehicle charging cable) of up to 5 m must not exceed 300 m Ω . For longer cables, the value can be increased in accordance with the applicable national regulations. In any case, the resistance must not exceed a value of 1 Ω .

- **Insulation test**

Two insulation measurements are required because the charging system is equipped with a disconnecting relay. The charging system must be disconnected from the power supply for this. Therefore, before the measurement, switch off the supply voltage using the circuit breaker in the building's electrical cabinet.

1. Measurement of the primary side of the charging system.

Measure the insulation resistance on the primary side of the charging system at the connection point of the power supply line to the charging system in the building's electrical cabinet. The value must not exceed 1 M Ω .

► **Note**

The Wallbox has a surge protector. This may be considered in the course of making measurements.

2. Measurement of the secondary side of the charging system.

For this, connect the charging coupler to a test adapter for vehicle simulation in accordance with EN 61581-1.

Measure the insulation via the measuring sockets on the test adapter. The value must not exceed 1 M Ω .

- Alternatively, the differential current method can be used in conjunction with measurement of the PE conductor current. In both cases, the value must not exceed 3.5 mA.

For these measurements, connect the charging coupler to a test adapter for vehicle simulation in accordance with EN 61581-1. The measurements must be carried out with the adapter in the C mode. Measure the differential current at the connection point of the power supply line to the charging system in the building's electrical cabinet.

- **Test of the power-off condition in case of a short-circuit (Z_{L-N})**

For these measurements, connect the charging coupler to a test adapter for vehicle simulation in accordance with EN 61581-1. The measurements must be carried out with the adapter in the C mode. Carry out the measurements on the measuring sockets of the test adapter. The values must comply with those of the selected circuit breaker.

- **Test of the power-off condition in case of a fault (Z_{L-PE})**

For these measurements, connect the charging coupler to a test adapter for vehicle simulation in accordance with EN 61581-1. The measurements must be carried out with the adapter in the C mode. Carry out the measurements on the measuring sockets of the test adapter with a suitable instrument. The values must comply with those of the selected circuit breaker.

- **Test of the integrated DC residual-current detection**

For these measurements, connect the charging coupler to a test adapter for vehicle simulation in accordance with EN 61581-1. The measurements must be carried out with the adapter in the C mode. Carry out the measurements on the measuring sockets of the test adapter with a suitable instrument. If the residual current is greater than 6 mA DC, the charging system must disconnect the charging coupler from the power supply. The fault indicator on the charging system must be activated.

- **Test of the integrated AC residual-current detection**

For these measurements, connect the charging coupler to a test adapter for vehicle simulation in accordance with EN 61581-1. The measurements must be carried out with the adapter in the C mode. Carry out the measurements on the measuring sockets of the test adapter with a suitable instrument. If the residual current is greater than 30 mA AC, the charging system must disconnect the charging coupler from the power supply. The tripping time must be less than 40 ms. The

fault indicator on the charging system must be activated. If the upstream RCDs are correctly dimensioned, this does not trip.

- **Test of the upstream RCD**

Due to the integrated AC residual-current detection, the upstream RCD must be tested at the connection point of the power supply line to the charging system in the building's electrical cabinet. The RCD must trip in accordance with the national regulations.

1.6 Specifications

Designation	Technical specifications
Regulations	IEC 61851-1
Charging capacity type 3	up to 11 kW
Nominal voltage	230 V / 400 V / 1/3 AC
Nominal current	up to 16 A adjustable from 6 A to 16 A in 2 A increments
Nominal frequency	50 Hz
Connection method	Spring clip method
Charging connection/charging coupler	Type 2
Length of charging cable	3.5, 5 m or 7.5 m
Operation/status information	Pushbutton with LED
Protection rating	IP54
Residual current detection	AC 30 mA, DC 6 mA
Ambient temperature	-25 °C to +40 °C
Ventilation	No ventilation required
Protection class	I
Overvoltage category	III
Weight	approx. 8 kg

Tab. 1

1.7 Protective devices



PS.110.1073-00GRAND_00

The following components are protective devices:

- 1 Housing
- 2 Charging cable
- 3 Protective cover
- 4 Charging coupler

Checking the protective devices

- 1. Before every charging process, make a visual inspection of the protective devices for damage.
- 2. Have a qualified electrician make regular electrical function tests in accordance with the national regulations.

Fig. 1 Charging system

1.8 Operator control elements

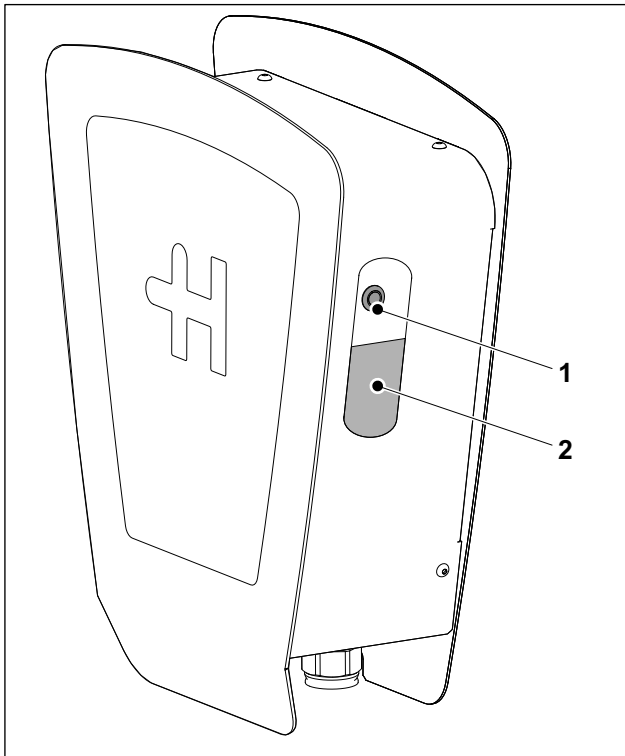

Fig. 2 Button/LED combination of the Heidelberg Wallbox Home ECO charging system

The charging system can be operated with a single button/LED combination (Fig. 2/1). An optional external blocking device (e.g. key switch) can be connected to the internal interface.

Functions of the LED

The LED indicates the operating state of the charging system. Detailed information on the operating states is given in the operating manual.

Functions of the button

The functions of the button are described in the operating manual.

Starting the charging process

The charging process starts automatically as soon as the charging coupler is plugged in and the vehicle requests a charging process.

Stopping the charging process

► **Note**

The charging process cannot be stopped with the button. There are 3 ways of stopping the charging process.

- Stop the charging process with the operating controls in the vehicle. Instructions on this are given in the vehicle's operating manual.
- or
- Disconnect the charging system from the power supply by switching off the respective circuit breaker in the building.
- or
- Disable the charging system using the optional external blocking device.

Optional external blocking device

If an external blocking device (e.g. key switch) is connected, the charging process is only started when the Wallbox has been enabled by the external blocking device.

1.9 Declaration of Conformity

The Declaration of Conformity and the CE marking on the product are valid for the following EU Member States:

Austria, Belgium, Bulgaria, Croatia, Cyprus, Czech Republic, Denmark, Estonia, Finland, France, Germany, Greece, Hungary, Ireland, Italy, Latvia, Lithuania, Luxembourg, Malta, Netherlands, Poland, Portugal, Romania, Slovakia, Slovenia, Spain, Sweden, United Kingdom

Heidelberg Wallbox Home Eco
Installation instructions

00.999.3023/01

HEIDELBERG

A Installation instructions

Installation instructions	A.1.1
1 Installation instructions	A.1.1
1.1 Safety	A.1.1
1.2 Prerequisites	A.1.1
1.3 Scope of supply/Enclosed accessories	A.1.1
1.4 Specifications	A.1.1
1.5 Mounting on the wall	A.1.2
1.6 Mounting on a column	A.1.5
1.7 Electrical connection	A.1.5
1.8 Commissioning	A.1.7
1.9 Contact address/Customer Sales Representative	A.1.8
1.10 Environment	A.1.8

00.110.9704-0000EN_02

1 Installation instructions

1.1 Safety

Before installing and starting up the Wallbox, please carefully read the enclosed safety instructions.

1.2 Prerequisites

- The Wallbox may only be operated when mounted vertically.
- If possible, the Wallbox should be mounted so that it is not directly exposed to rain e.g. to prevent icing, being damaged by hail or similar. Do not expose the Wallbox to direct sunlight because this can cause it to overheat.
- The individual phases of the supply voltage must each be protected with residual current devices and circuit breakers.
- No single wires may be used for power supply.
- The diameter of the supply line must be between 9 mm and 17 mm.
- The charging current of the Wallbox must be set in accordance with the building's circuit breakers. (The procedure is described in the "Electrical connection" section.)

1.3 Scope of supply/Enclosed accessories

- Mounting plate with electronics housing,
- Wallbox housing cover,
- 4x fillister head screws M4x10 (to attach the housing cover of the Wallbox),
- Cable gland ESKV25 (cable entry for power supply),
- Gasket EADR25, for cable gland ESKV25,
- Device documentation (safety instructions, installation instructions, operating manual).

1.4 Specifications

Designation	Technical specifications
Regulations	IEC 61851-1
Charging capacity type 3	up to 11 kW
Nominal voltage	230 V / 400 V / 1/3 AC

Designation	Technical specifications
Nominal current	up to 16 A adjustable from 6 A to 16 A in 2 A increments
Nominal frequency	50 Hz
Connection method	Spring clip method
Charging connection/ coupler	Type 2
Length of charging cable	3.5, 5 m or 7.5 m
Operation/status informa- tion	Pushbutton with LED
Protection rating	IP54
Residual current detection	AC 30 mA, DC 6 mA
Ventilation	No ventilation required
Ambient temperature	-25 C to +40 C
Protection class	I
Overvoltage category	III
Weight	approx. 8 kg

Tab. 1

1.5 Mounting on the wall



Note

The following drilling plan is not to scale. It may not be used as a drilling template.

Please use only the specified dimensions from the drilling plan.

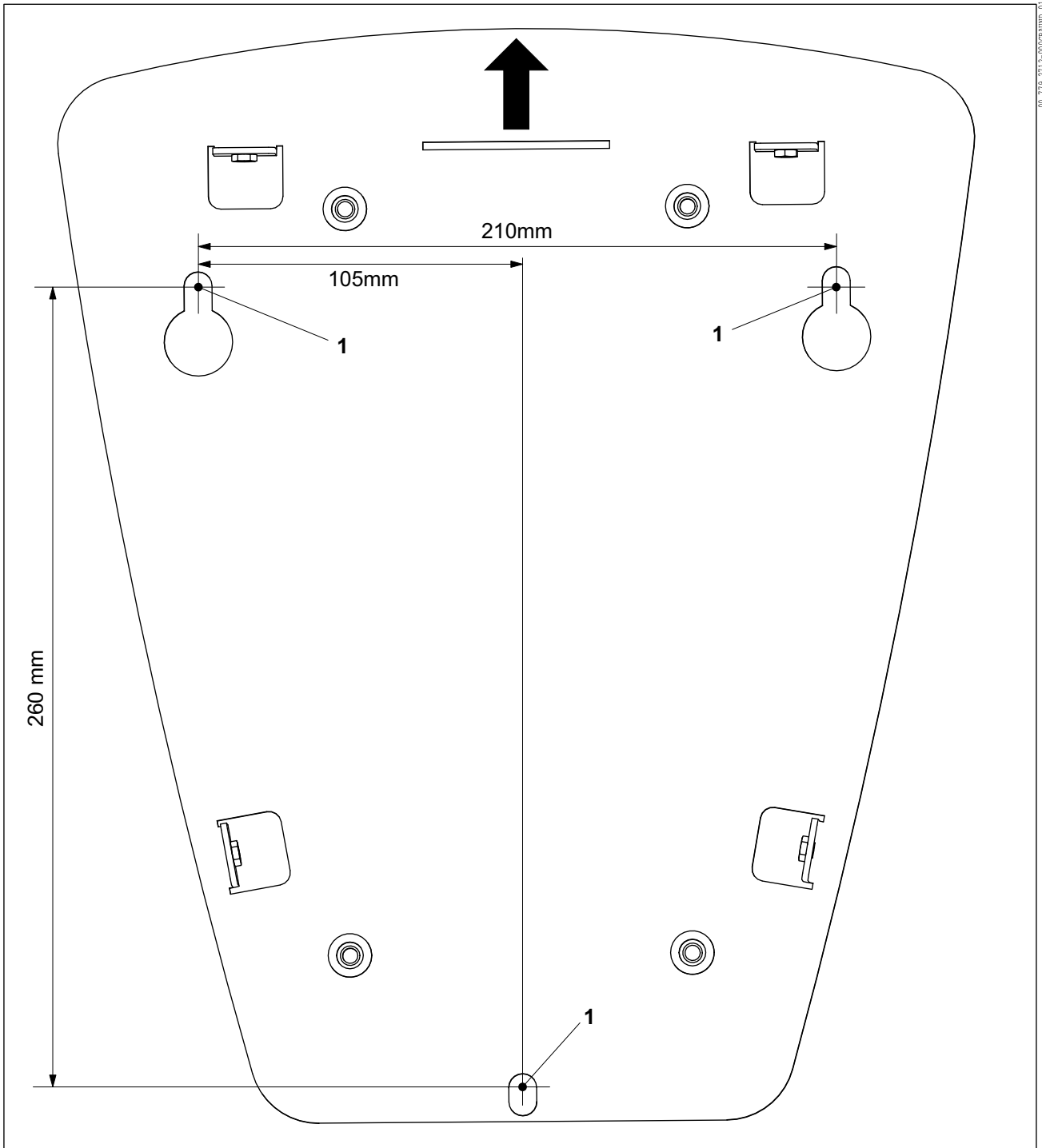

00.779.2712-00GRAND_01

Fig. 1 Drilling plan for the Heidelberg Wallbox Home Eco

Prerequisites

Recommended mounting height above the floor is 1.00 m -1.10 m up to the lower hole.

The mounted Wallbox must be able to withstand a load of at least 16 kg.

Installation steps

1. Mark the three mounting holes (Fig. 1/1) as shown on the drilling plan.
2. Drill and prepare the mounting holes according to the type of mounting surface (e.g. dowels for masonry). The screw diameter must not exceed 8 mm.
3. Screw in the two top fastening screws.

► Note

The fastening screws are not included in the scope of delivery due to the different types of mounting surfaces.

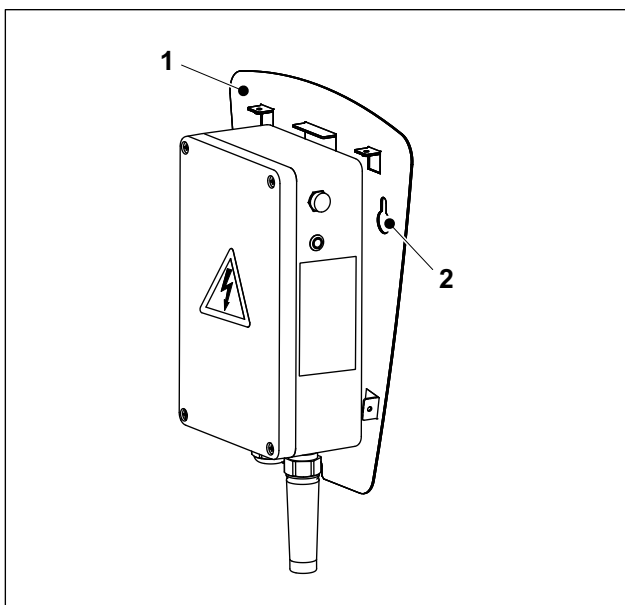

Fig. 2 Heidelberg Wallbox Home Eco, mounting plate

4. Hang the mounting plate (Fig. 2/1) of the Wallbox on the two fastening screws (slotted holes, Fig. 2/2).
5. Screw the third fastening screw into the lower hole.
6. Tighten the three fastening screws (approx. 12 Nm).

1.6 Mounting on a column

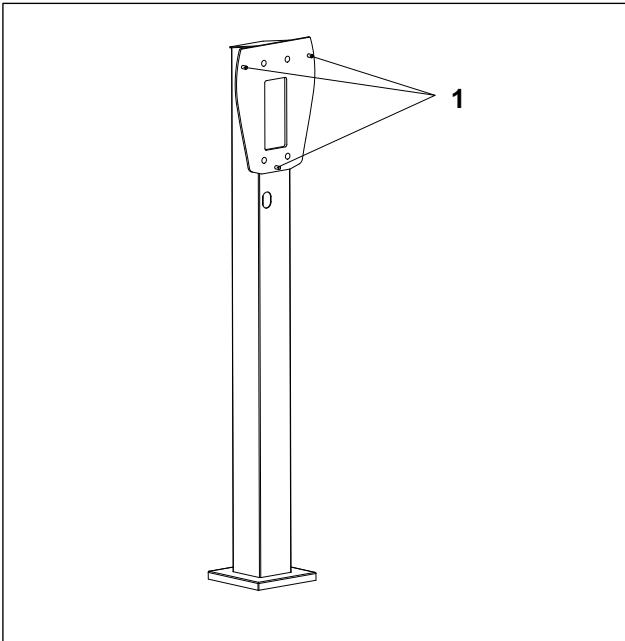

Fig. 3 Column with three attachment points

1. Hang the mounting plate of the Wallbox (Fig. 2/1) on the three stud bolts of the column (Fig. 3/1).
2. Screw the three nuts (separate parts set for the column) on the stud bolts (Fig. 3/1) and tighten (approx. 12 Nm).

1.7 Electrical connection

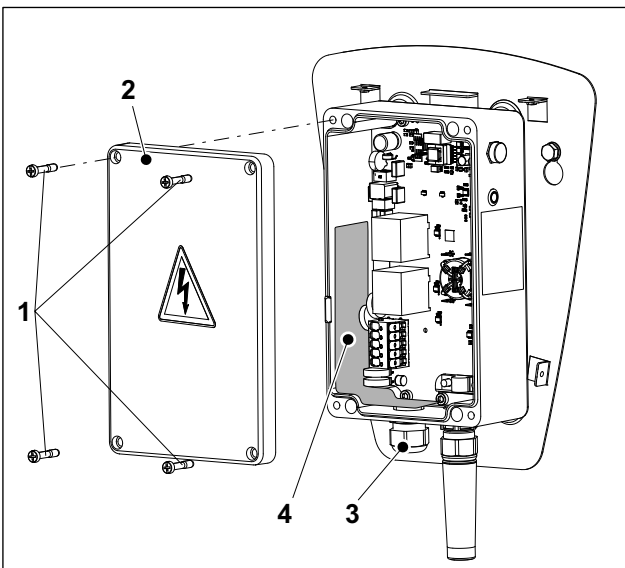

Fig. 4 Heidelberg Wallbox Home Eco, opened electronics housing

Prerequisites

The Wallbox can be connected with a single phase 1 AC 230 V or with three phases 3 AC 400 V.

1. Remove the four screws (Fig. 4/1) and take off the cover of the electronics housing (Fig. 4/2).
2. Screw the cable gland ESKV25 (enclosed accessories) with the respective gasket EADR25 (enclosed accessories) into the electronics housing (Fig. 4/3) and tighten (approx. 8 Nm).
3. Strip off maximum 13 cm jacket from the power supply cable.
4. Strip off approx. 11 to 13 mm insulation from the individual wires.
5. Follow the instructions on the sticker (Fig. 4/4) and then pierce the sticker on the cable entry.
6. Insert the connecting line into the cable gland.
7. Tighten the cap nuts of the cable gland (approx. 4 Nm).

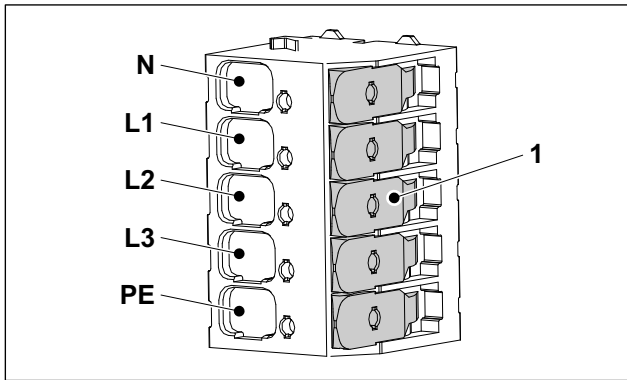

Fig. 5 Terminal clamps of the power supply unit



Caution - Heed the terminal sequence.

When clamping the connecting line, heed the sequence of the terminals. PE, L3, L2, L1, N.

Reverse polarity of the electrical connecting lines will destroy the electronics in the Wallbox!

8. Connect the individual wires of the power supply cable as shown in the diagram (Fig. 5). If a single-phase supply voltage is used, it must be connected to L1. Terminals L2 and L3 are not used for a single-phase connection.



Note

This is a tool-free terminal strip. Folding back the clamping lever (Fig. 5/1) opens the terminal so that the respective individual wire can be inserted. The respective clamping lever is then shut to secure the respective individual wire. Folding back more than one clamping lever at a time must be avoided.

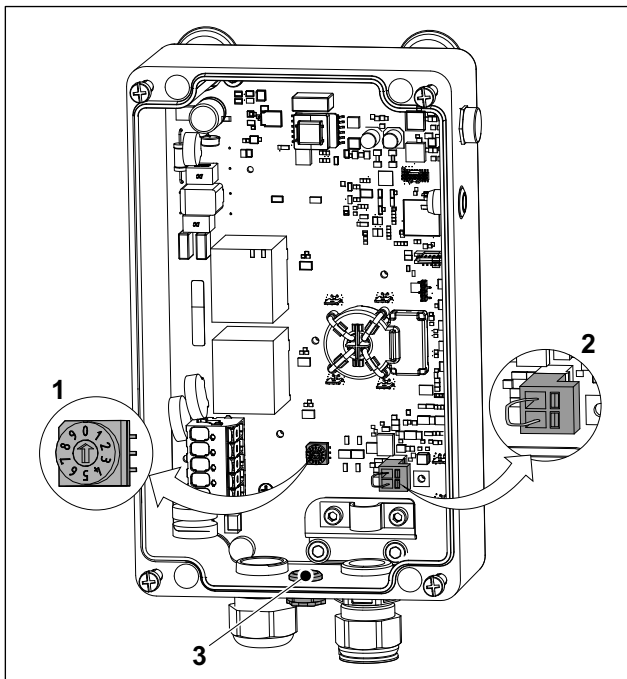

Fig. 6 Opened electronics housing

Setting the charging current

The charging current of the Wallbox must be set in accordance with the building's circuit breakers. Under no circumstances may the charging current be set higher than the respective circuit breaker.

The rotary switch (Fig. 6/1) is used to set the charging current from 6 to 16 A.

0	6 A (default setting, delivery state)
1	8 A
2	10 A
3	12 A
4	14 A
5 ... 9	16 A

External enabling/disabling of the Wallbox

The Wallbox can be optionally disabled or enabled by means of external switching elements (e.g. key switch). For this, the plug (Fig. 6/2) in the electronics housing must be pulled out and the wire jumper removed. The now vacant contacts of the plug must then be connected to a two-pole lead that exits through the cable entry (Fig. 6/3) to the corresponding switching element.

The contacts of the switching element must be dimensioned so that they can switch zero-potential currents of approx. 30 mA/12 V.

9. Replace the lid of the electronics housing (Fig. 4/2) and tighten the four screws (2.5 Nm).
10. Replace the cover, fasten it with the four screws M4x10 (Fig. 7/1) and tighten them (1.8 Nm). The four screws are included in the enclosed accessories.

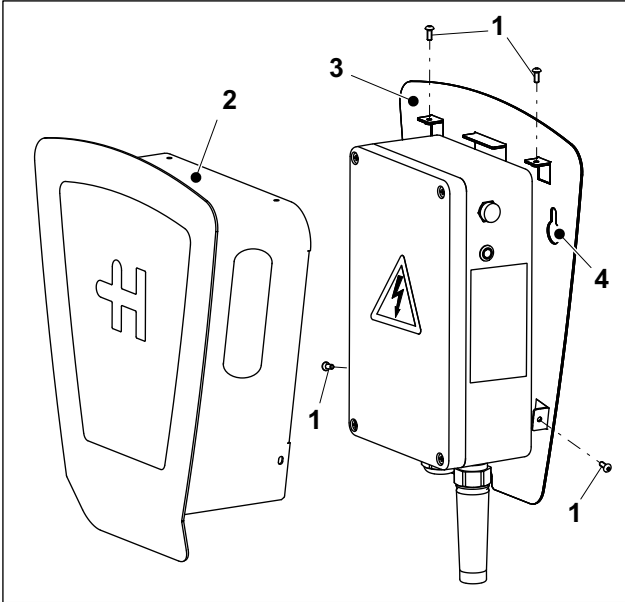

Fig. 7 Heidelberg Wallbox Home Eco with cover

1.8 Commissioning

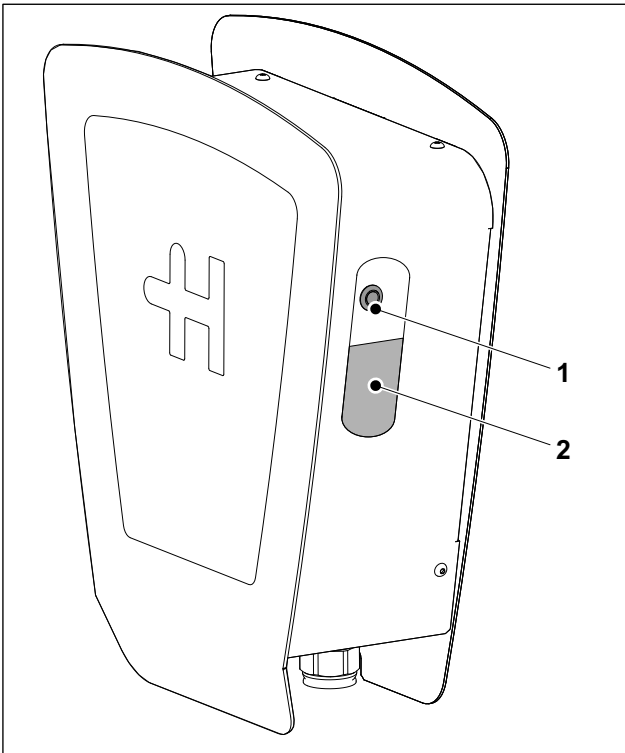

Fig. 8 Heidelberg Wallbox Home Eco

- 1 Pushbutton/LED combination
 - 2 Nameplate
1. Provide power to the Wallbox.

Once the Wallbox is connected to the mains, the LED (Fig. 8/1) lights up green.

After approx. 12 min in the ready mode without being connected to a vehicle, the Wallbox changes into the standby mode and the LED goes out.

Wake up option 1:

- When the charging cable is plugged into the vehicle while the Wallbox is in the standby mode, it automatically switches to the ready mode. The LED lights up green.

Wake up option 2:

- When the button is pressed (without connected vehicle), the Wallbox changes from the standby mode to the ready mode. The LED lights up green and the charging cable can now be plugged into the vehicle.

As soon as the vehicle requests a charging process, the Wallbox enables the charging process and the LED (Fig. 8/1) blinks green.

- ▶ **Note**
If an external blocking device is used, when the vehicle is connected, it checks whether there is an external block (e.g. by means of a key switch or similar). As long as the external device has not enabled the Wallbox, the LED lights up yellow and no charging takes place. After the external device has enabled the Wallbox, the LED lights up green.
- ▶ **Note**
The procedure in case of a malfunction (LED lights up/blinks yellow or red) is described in the operating manual of the Wallbox.

1.9 Contact address/Customer Sales Representative

Hotline: +49 6222 82-2266

E-mail Wallbox@heidelberg.com

Contact language: German and English.

Website: <https://wallbox.heidelberg.com/>

1.10 Environment

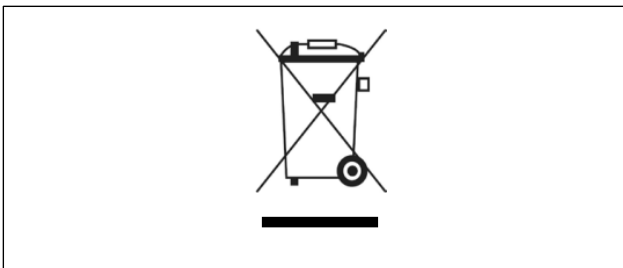

Fig. 9

This device is used for charging electrically powered vehicles and is thus regulated by EU Directive 2012/19/EU on waste electrical and electronic equipment (WEEE).

Its disposal must comply with the national and regional regulations for electrical and electronic equipment.

Waste equipment and batteries must not be disposed of by putting them in household or bulky waste. The device should be made inoperative before disposal.

Please dispose of the packaging material in the usual collection containers for cardboard, paper, and plastics for your region.

Heidelberg Wallbox Home Eco
Operating manual

00.999.3018/01

HEIDELBERG

A Operating manual

Operating manual	A.1.1
1 Operating manual	A.1.1
1.1 Safety	A.1.1
1.2 Cleaning the Wallbox	A.1.1
1.3 Specifications	A.1.1
1.4 Operation	A.1.2
1.5 Diagnostics	A.1.3
1.6 Contact address/Customer Sales Representative	A.1.4
1.7 Environment	A.1.4

00.110.9714-000FREN_02

1 Operating manual

1.1 Safety

Before installing and starting up the Wallbox, please carefully read the enclosed safety instructions.

1.2 Cleaning the Wallbox

Do not use any aggressive cleaners (e.g. benzine solvents, acetone, ethanol, spirit glass cleaner) to clean the Wallbox and especially the plastic panel. These can attack/damage the surface.

Permissible cleaners are mild detergent solutions (rinsing solution, neutral cleaner) and a soft, moistened cloth.

1.3 Specifications

Designation	Technical specifications
Regulations	IEC 61851-1
Charging capacity type 3	up to 11 kW
Nominal voltage	230 V / 400 V / 1/3 AC
Nominal current	up to 16 A adjustable from 6 A to 16 A in 2 A increments
Nominal frequency	50 Hz
Connection method	Spring clip method
Charging connection/ coupler	Type 2
Length of charging cable	3.5 m, 5 m or 7.5 m
Operation/status information	Pushbutton with LED
Protection rating	IP54
Residual current detection	AC 30 mA, DC 6 mA
Ambient temperature	-25 C to +40 C
Ventilation	No ventilation required
Protection class	I
Overvoltage category	III
Weight	approx. 8 kg

Tab. 1

1.4 Operation

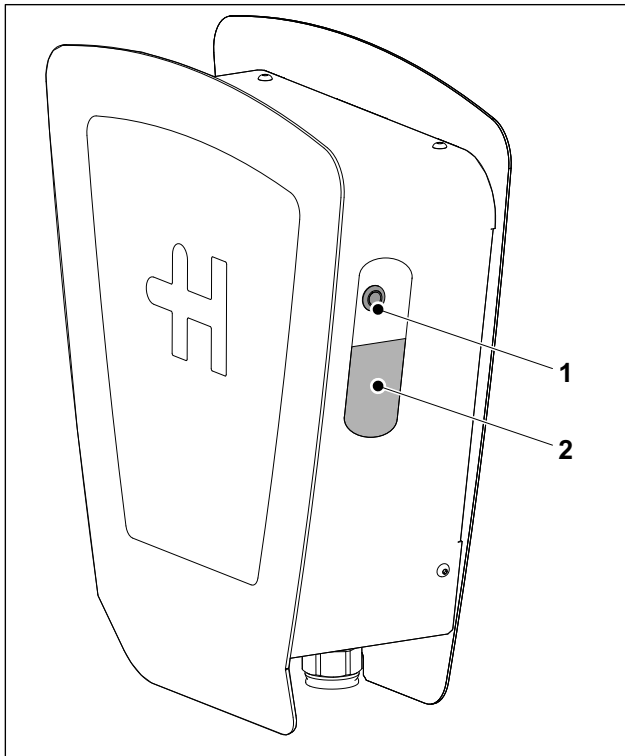

Fig. 1 Heidelberg Wallbox Home Eco

1 Pushbutton/LED combination

2 Nameplate

1. Completely unwind the charging cable from the Wallbox.
2. Remove the cover from the coupler of the charging cable.
3. Plug the charging cable into the vehicle.

As soon as you have plugged the charging cable into the vehicle, the Wallbox switches to "ready" and the LED lights up green.

After approx. 12 min in the ready mode without being connected to a vehicle, the Wallbox changes into the standby mode and the LED goes out.

Wake up option 1:

- When the charging cable is plugged into the vehicle while the Wallbox is in the standby mode, it automatically switches to the ready mode. The LED lights up green.

Wake up option 2:

- When the button is pressed (without connected vehicle), the Wallbox changes from the standby mode to the ready mode. The LED lights up green and the charging cable can now be plugged into the vehicle.

► **Note**

If an external blocking device is used, when the vehicle is connected, it checks whether there is an external block (e.g. by means of a key switch or similar). As long as the external device has not enabled the Wallbox, the LED lights up yellow and no charging takes place. After the external device has enabled the Wallbox, the LED lights up green.

Charging process

When you have plugged in the charging cable, charging of the vehicle can start. The LED blinks green during charging.

When the vehicle has stopped charging, the Wallbox terminates the charging process. The LED lights up green.

These two operating statuses may be repeated a number of times during a complete charging cycle.

End of charging

When the charging process is finished, you must unplug the charging cable from the vehicle and close the cover on the cable. You must then wind up the charging cable onto the Wallbox.

► **Note**

If the charging cable is not wound up and lies loosely on the ground, someone may trip over it.

When winding the cable, make sure you do not pull it too hard or wind it too tightly. Repeatedly pulling too hard or winding too tightly can lead to cable breakages.

Stopping the charging process

The charging process **cannot** be stopped with the button (Fig. 1/1). There are three ways of stopping the charging process:

- Stop the charging process with the vehicle's operating controls. Instructions on this are given in the vehicle's operating manual.
- Disconnect the Wallbox from the power supply by disengaging the building's circuit breakers.
- If the Wallbox has an external blocking device, you can use it to stop the charging process.

1.5 Diagnostics

Wallbox does not react

If the Wallbox does not react after the charging cable has been plugged in or after pressing the button (Fig. 1/1), please check the building's power supply (circuit breakers, residual current circuit breaker).

LED lights up yellow

If an external blocking device is used, when the vehicle is connected, it checks whether there is an external block (e.g. by means of a key switch or similar). As long as the external device has not enabled the Wallbox, the LED lights up yellow and no charging takes place.

- Switch off the external blocking device.

After the external device has enabled the Wallbox, the LED lights up green.

LED blinks alternately yellow/red:

Residual current circuit breaker in the Wallbox has been triggered.

- Make a visual inspection of the Wallbox, the charging cable, and the vehicle.
- To reset the residual current circuit breaker, press the button (Fig. 1/1) for longer than 3 seconds. The LED flashes green.

After approx. 4 seconds, the Wallbox is ready for operation and the LED lights up green.

LED blinks yellow (blink sequence 50 % on / 50 % off)

Possible cause of the fault: overheating.

- You do not need to intervene.

After a self-test and elimination of the malfunction, the LED lights up green.

LED blinks yellow (blink sequence 90 % on / 10 % off)

Possible cause of the fault: supply voltage is too high or too low.

- You do not need to intervene.

After a self-test and elimination of the malfunction, the LED lights up green.

LED blinks yellow (blink sequence 10 % on / 90 % off)

Faulty communication with the vehicle or the maximum preset current has been exceeded.

- Check that the charging cable is correctly plugged into the vehicle.

After a self-test and elimination of the malfunction, the LED lights up green.

LED lights up continuously red:

Internal malfunction of the Wallbox.

- Disconnect the charging cable from the vehicle.
- Disconnect the Wallbox from the power supply by switching off the respective circuit breakers of the building.

Wait approx. 1 minute and then re-engage the circuit breakers.

After a self-test and elimination of the malfunction, the LED lights up green.

- Reconnect the charging cable to the vehicle.

Troubleshooting

If the above malfunctions continue, please contact our hotline.

1.6 Contact address/Customer Sales Representative

Hotline: +496222 82 2266

E-mail Wallbox@heidelberg.com

Contact language: German and English.

Website: <https://wallbox.heidelberg.com/>

1.7 Environment

Fig. 2

This device is used for charging electrically powered vehicles and is thus regulated by EU Directive 2012/19/EU on waste electrical and electronic equipment (WEEE).

Its disposal must comply with the national and regional regulations for electrical and electronic equipment.

Waste equipment and batteries must not be disposed of by putting them in household or bulky waste. The device should be made inoperative before disposal.

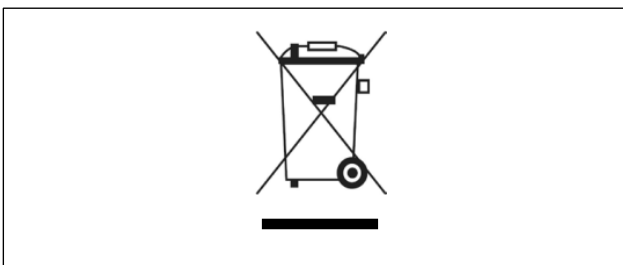
Please dispose of the packaging material in the usual collection containers for cardboard, paper, and plastics for your region.